

# APOLLO

C o r p o r a t i o n

## Advantage™ Bathing System 6000/6300 Specifications

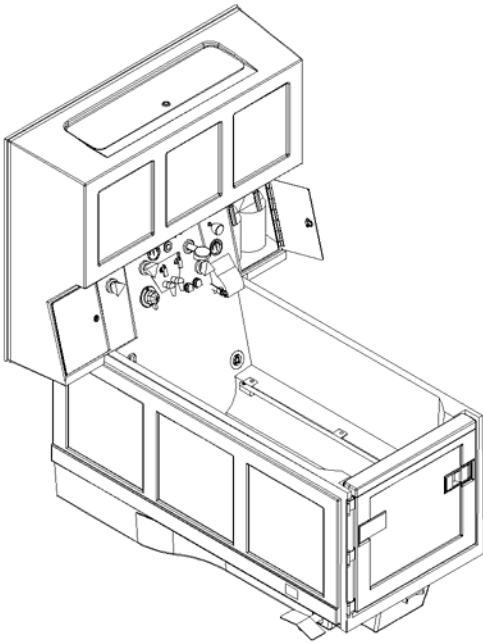

6000 Series

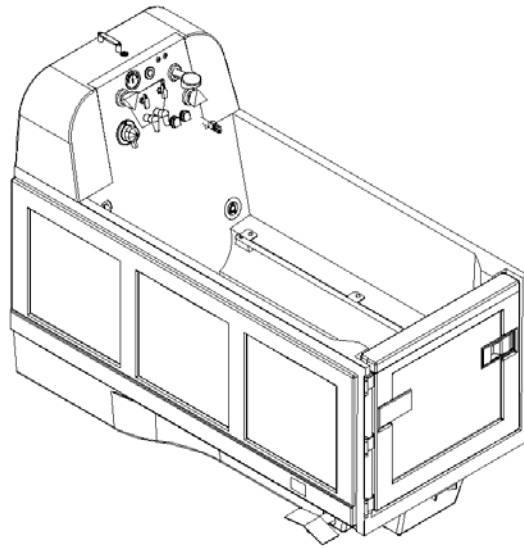

6300 Series

450 Main Street  
Phone: 715.247.5625

PO Box 219  
Fax: 715.247.3424

Somerset, WI 54025  
[www.apollobath.com](http://www.apollobath.com)

## Plumbing and Electrical Codes

All states and municipalities could differ extensively in their plumbing and electrical codes. Therefore, it is Apollo Corporation's recommendation that you check with the proper enforcement agencies in your area before installation.

All Apollo bathing systems are manufactured with built-in backflow prevention. However, due to different plumbing codes, it is advisable that you ask your installer whether there is a need to install additional backflow prevention valves (such as RPZ valves) on any new construction.



### NOTE

- Lock Out or Tag Out electrical circuit for bathing system BEFORE installation.
- Electrical Protection: Class 1 Type B applied part.
- Bathing system installation must comply with all applicable building and health codes and regulations.
- It is recommended that hot water not greater than 120°F be delivered to the bathing system.

## Apollo Advantage™ Bathing System 6000/6300 Specifications

**Minimum Room Size:** 72" (182.9 cm) wide by 108" (274.3 cm) long      **Space Saver** 72" (182.9 cm) wide by 96" (243.8 cm) long

<b>Dimensions:</b>	<b>Length</b>	<b>Width</b>	<b>Height (All)</b>
<b>Tub:</b>	71" (180.3 cm)	34" (86.5 cm)	36" (91.4 cm) Side of Tub
<b>Space Saver:</b>	59" (149.8 cm)	34" (86.5 cm)	50" (127.0 cm) at Control Panel Top
<b>Cabinet:</b>	17" (43.2 cm) Deep	56" (142.2 cm)	81" (205.7 cm) Max installed (Reservoir)
<b>Level Glide™ Carrier:</b>	32.5" (82.5 cm)	23.75" (60.3cm)	40" (101.6 cm)

**Installed Length:** Door Closed: 71" (180.3 cm)      Door Open: 102" (259.1 cm)  
**Space Saver:** Door Closed: 59" (149.8 cm)      Door Open: 90" (228.6 cm)

**Component Weight:** Tub 289 lb (131 kg)      Cabinet 183 lb (83 kg)  
 Level Glide™ w/o Scale 83 lb (38 kg)      Level Glide™ with Scale 118 lb (53.5 kg)

**Total Shipping Weight:** 845 lb (384 kg)

**Water Supply:** Requires (2) ¾" (1.9 cm) garden hose thread (GHT) wall mounted faucets.  
 Minimum of 30 PSI for hot and cold required.

**Water Connection:** Provided with two (2) 60" (152.4 cm) high pressure stainless steel hoses with ¾" (1.9 cm) GHT ends.

**Waste:** 2" (5.1 cm) PVC schedule 40 pipe. Outside diameter 2.4" (6.1 cm)

**Electrical:** Dedicated 115 VAC plug-in receptacle protected by a 15A GFCI circuit breaker (not supplied).

**Whirlpool Pump Motor:** ¾ HP; 9A; 115 VAC; 60HZ; 3400 RPM; 100 GPM at zero head.

**Air Spa Blower Motor:** 900 W variable speed, thermally protected blower motor with 300W ceramic heating element, 120 VAC; 11A; 60 HZ.

**Whirlpool Control:** Pneumatic pushbutton switch.

**Air Spa Control:** Multifunction, low voltage DC electronic keypad

**Whirlpool Jets:** Four whirlpool jets with adjustable nozzles.

**Air Spa Jets:** Twelve total air jets, four seat jets with 6 lateral openings each and 8 vertical jets with 24 openings each.

**Tub Fill:** RADA Thermoscopic mixing valve; ASSE 1016 certified.

**Shower:** Hand held with 84" (213.4 cm) ANSI A112.18.1 hose and ASSE 1014 Vacuum Breaker

**Tub Entry:** Door with 24.5" (62.2 cm) opening where residents are transferred into tub.

**Gaskets:** Dual gaskets extruded from EDPM Neoprene.

**Installation Time:** 1-½ Hours

**Inspection & Adjustments:** 1 Hour

**Reservoir Capacity:** Maximum of 65 gal (247 L)

**Whirlpool Water Requirement:** 54 gal (205 L) (Space Saver 47 gal or 178 L) minimum required to run whirlpool jets without resident.

**Air Spa Water Requirement:** None

### Level Glide™ Transfer System

**Carrier:** Heavy duty stainless steel.

**Casters:** Four heavy-duty, medical grade, stainless steel ball bearing swivel casters with 4" (10 cm) non-marring wheels. Two of the casters have toe released brakes.

**Chair:** Stainless steel frame with plastic contoured seat and back.

**Safety Straps:** 2 safety straps.

**Capacity:** 400 lb (181 kg)

**Safety Locks:** Chair single lock to release chair from track stops. Dual secondary locks that release during transfer into tub.

**\*Specifications subject to change**

## Bathing Room Preparation

- **Plan Bathing System Location.**

### **!WARNING!**

- Floor must be flat and level for Level Glide™ Transfer System to operate correctly. Choose the flattest floor location possible.
- Rails must align to prevent chair derailment.
- Level Glide™ Transfer System must lock securely to avoid separation from the tub.

### **CAUTION**

- Bathing room characteristics; including room dimensions, door sizes and floor drain placement, must comply with all applicable building and health codes.

### **NOTE**

- Clearance of 18” or more is recommended for ease of use and serviceability.
- A floor drain is recommended in the bathing room in case an emergency evacuation is required. Drain should not be in a place where it will interfere with resident transfer.
- Be sure cabinet does not cover switches, valves, or other items that must be reached by attendants or patients.

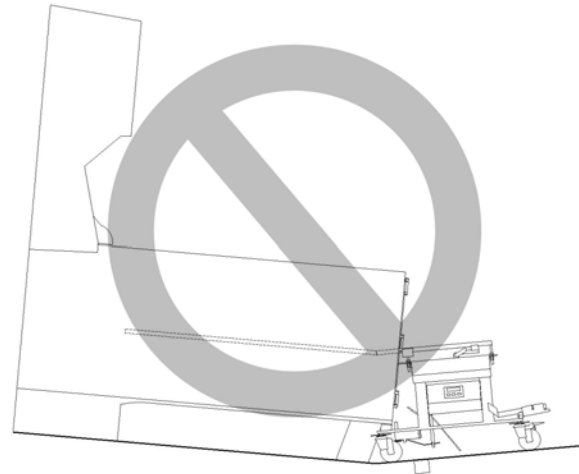
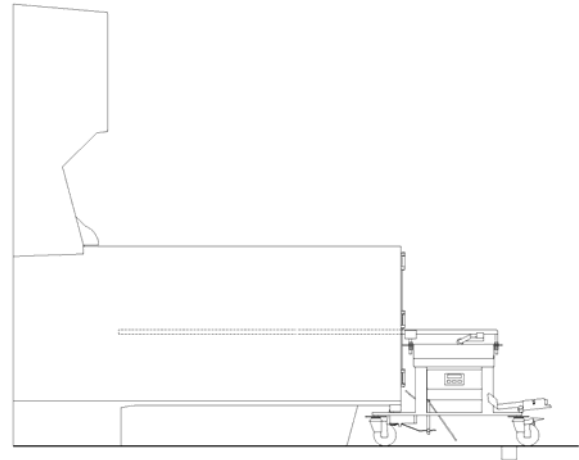

# Bathing System Dimensions

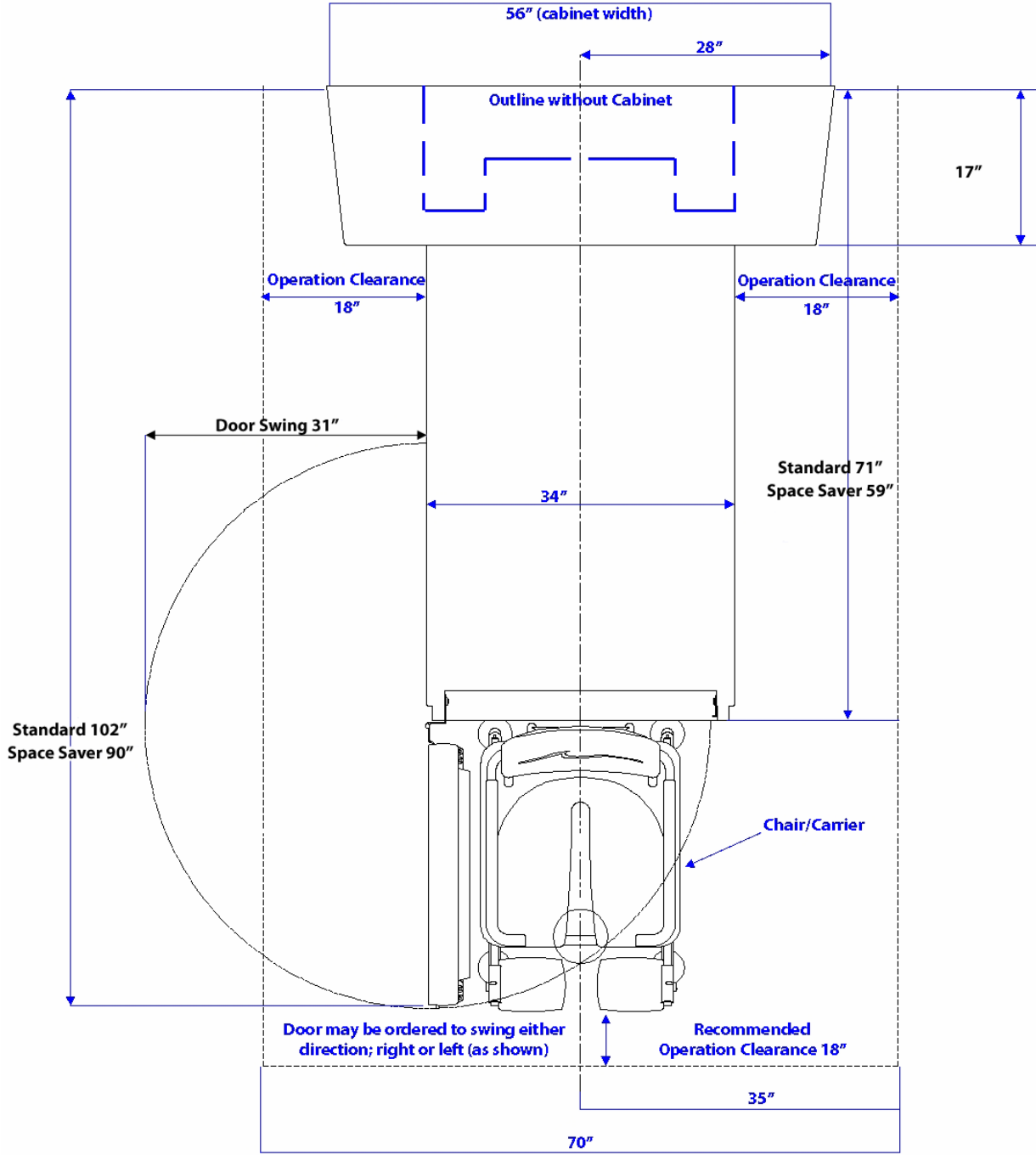

- **Mark tub center line on walls and floor.**

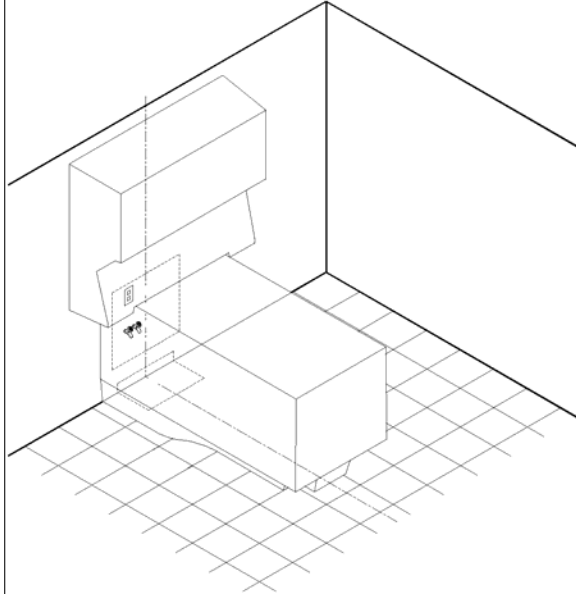

- **Install electrical service.**

### **!WARNING!**

- Electrical current can cause severe injury or death.
- Turn off power breaker.
- Lock circuit open to prevent accidental activation.
- Electrical service must be located higher than the plumbing service.
- Install a Class A Ground Fault Interrupter (GFI) between the bathing system and the incoming electrical power supply. GFI must be easily accessible to reset if needed.

### **NOTE**

- Recommended service for U.S. grounded 120 VAC, 15A with Class A Ground Fault Interrupter (GFI) to be supplied by facility's electrician.
- Electrical outlet for the Whirlpool or Air Spa must not have a built-in GFI.
- Electrical wiring must comply with all applicable building and electrical codes. A licensed electrician may be required to install this service.

- **Install plumbing service.**

Minimum required water pressure: 30 PSI for both hot and cold.

### **CAUTION**

Wall and floor openings used to install electrical and plumbing connections should be closed and sealed to help maintain sanitary conditions.

### **NOTE**

- Plumbing service must comply with all applicable building and plumbing codes. A licensed plumber may be required to install this service.
- Local plumbing codes may require a backflow preventer to be installed in both hot and cold water supply lines.

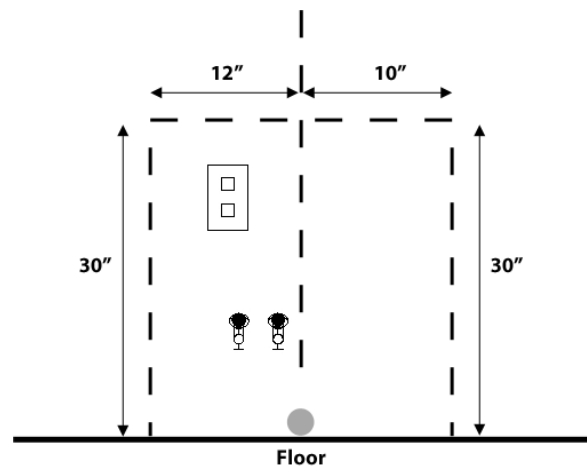

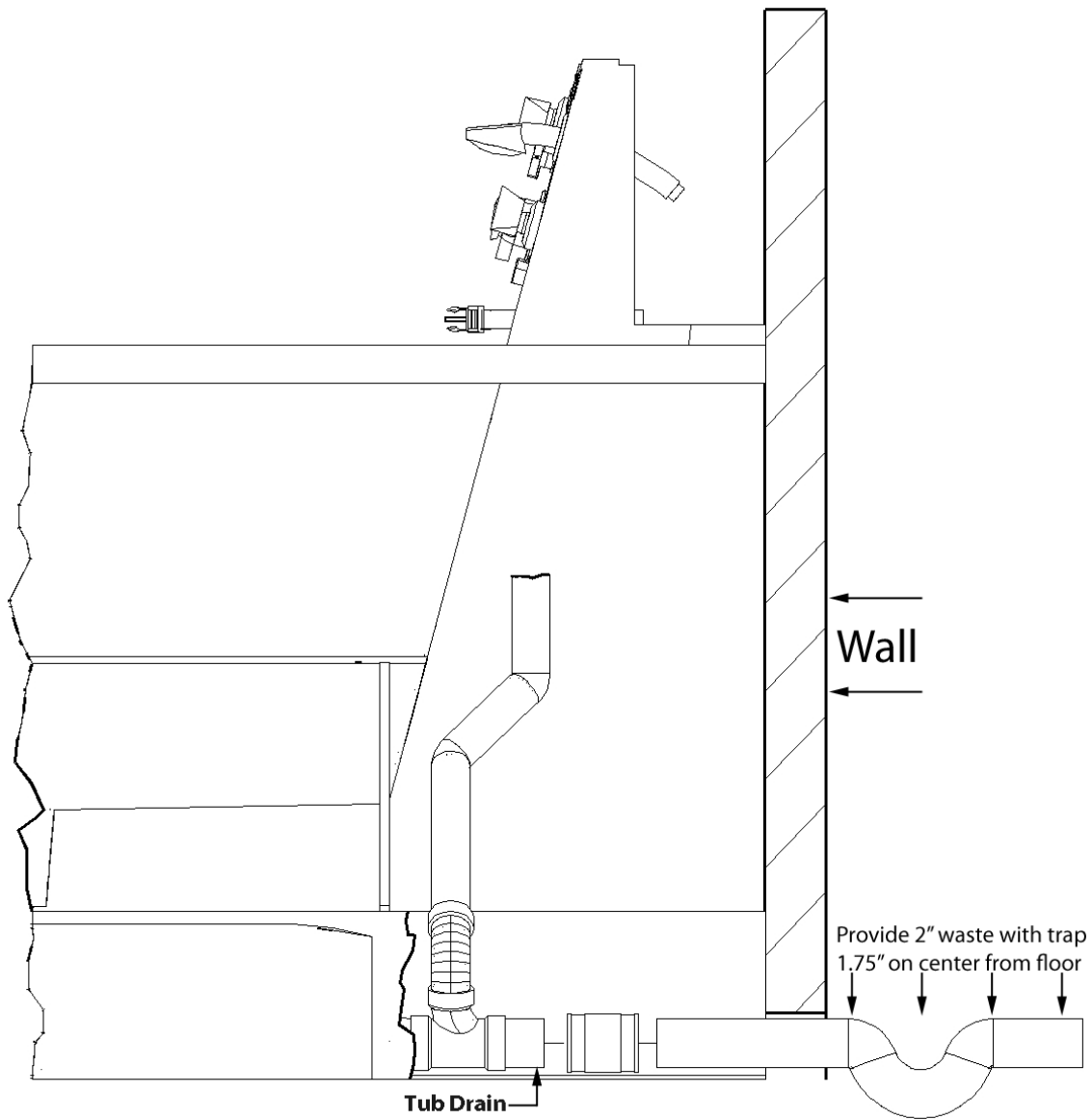

**Standard drain connection is usually PVC coupling or Fernco coupler. Another option is to drop into a floor sink. \*Be sure to consult local regulations.**