

# APOLLO

C o r p o r a t i o n

## Essence™ Spa Specifications

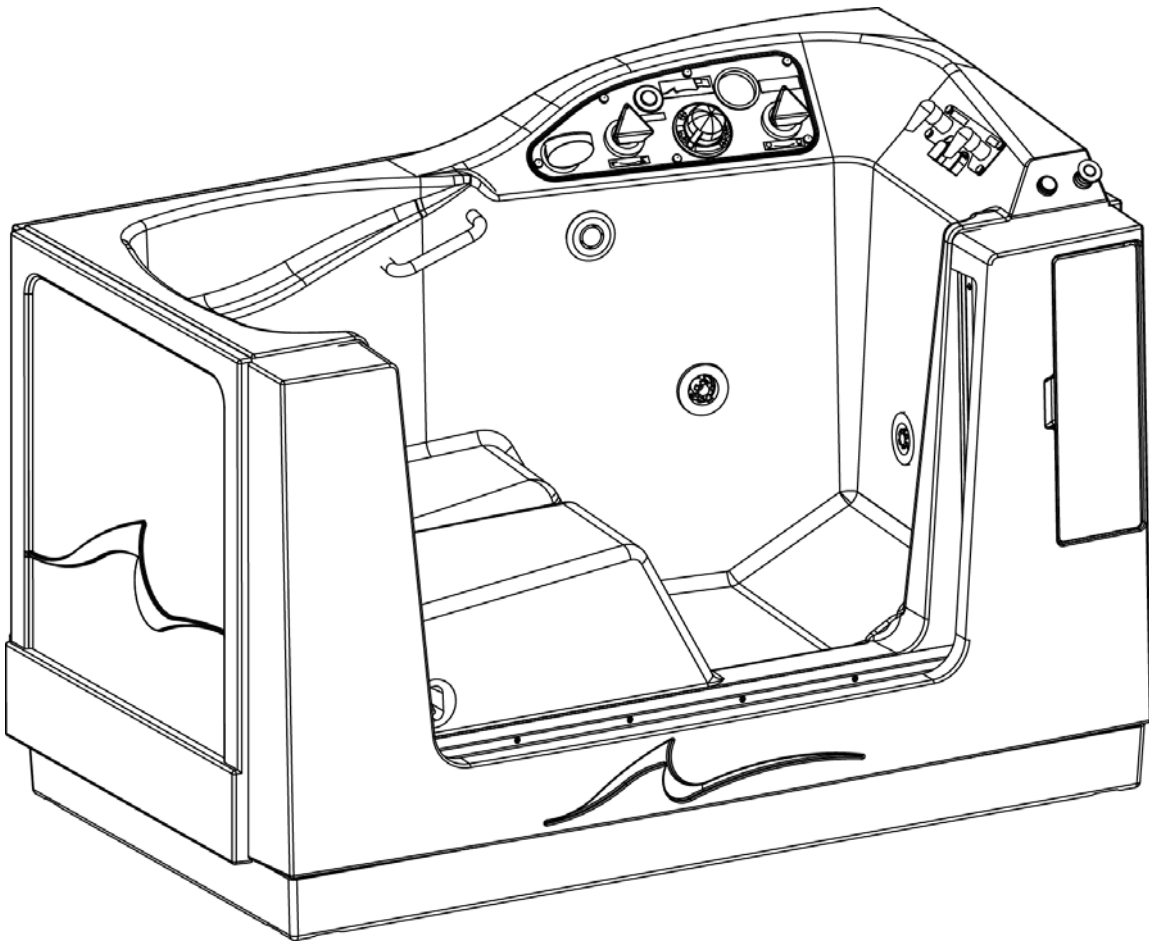

450 Main Street  
Phone: 715.247.5625

PO Box 219  
Fax: 715.247.3424

Somerset, WI 54025  
[www.apollobath.com](http://www.apollobath.com)

## Plumbing and Electrical Codes

All states and municipalities could differ extensively in their plumbing and electrical codes. Therefore, it is Apollo Corporation's recommendation that you check with the proper enforcement agencies in your area before installation.

All Apollo bathing systems are manufactured with built-in backflow prevention. However, due to different plumbing codes, it is advisable that you ask your installer whether there is a need to install additional backflow prevention valves (such as RPZ valves) on any new construction.



### NOTE

- Lock Out or Tag Out electrical circuit for bathing system BEFORE installation.
- Electrical Protection: Class 1 Type B applied part.
- Bathing system installation must comply with all applicable building and health codes and regulations.
- It is recommended that hot water not greater than 120°F be delivered to the bathing system.

## Apollo Essence™ Spa Specifications

**Minimum Room Size:** 69" (183 cm) wide by 90" (228.6 cm) long

<b>Dimensions:</b>	<b>Length</b>	<b>Width</b>	<b>Height</b>
<b>Tub:</b>	59.51" (151.1 cm)	33.63" (85.4 cm)	40.75" (103.5 cm)
<b>With Side Panels:</b>	61.63" (156.5 cm)	34.88" (88.6 cm)	40.75" (103.5 cm)
<b>Shipping Weight:</b>	500 lb (227 kg)		

**Water Supply:** Requires (2) ¾" (1.9 cm) garden hose thread (GHT) internal, wall, or floor mounted faucets. Minimum of 30 PSI for hot and cold required.

**Water Connection:** Provided with two (2) 60" (152.4 cm) high pressure stainless steel hoses with ¾" (1.9 cm) GHT ends.  
**Waste:** Two 1.5" (3.8 cm) PVC schedule 40 pipe. Outside diameter 1.9" (4.8 cm)

**Electrical Requirements:** Dedicated 115 VAC plug-in receptacle protected by a 15A GFCI circuit breaker (not supplied).

**Whirlpool Pump and Motor:** ¾ HP; 7.5A; 115 VAC; 60HZ; 3370 RPM; 86 GPM at zero head.

**Air Spa Blower Motor:** 900 W variable speed, thermally protected blower motor with 300W ceramic heating element, 120 VAC; 11.5A; 60 HZ.

**Door Control:** 24 VDC maintained, IP 65, dustproof, water resistant, sealed push-button switch for operation of powered door. Emergency release for door in case of power failure.

**Whirlpool Control:** On-Off pneumatic switch

**Air Spa Control:** Multifunction, low voltage DC electronic keypad

**Whirlpool Jets:** Four whirlpool jets with adjustable nozzles.

**Air Spa Jets:** 20 total air jets: Five seat and four leg jets with 24 openings each. One perineal and ten foot well jets with six lateral openings each.

**Tub Fill:** RADA Thermoscopic mixing valve; ASSE 1016 certified.

**Shower:** Hand held with 84" (213.4 cm) ANSI A112.18.1 hose.

**Tub Entry:** Door with 40" (101.6 cm) opening and 10.25" (26.0 cm) entry height.

**Gaskets:** Dual gaskets extruded from EDPM.

**Installation Time:** 1-½ Hours

**Inspection & Adjustments:** 1 Hour

**Capacity:** Maximum of 63 gal (238 L)

**Whirlpool Water Requirement:** 36 gal (136 L) minimum required to run whirlpool jets without resident.

**Air Spa Water Requirement:** None

**\*Specifications subject to change**

### Important Installation Highlights

- This bathing system is designed to be installed **AFTER** all construction and finish work is completed.
- During and after installation this bathing system **DOOR** needs to be in the **UP** position.
- This bathing system comes with a catch pan that will collect any residual water from the bathing process. It has a drain hole located in the right hand bottom back corner as you face the front of the unit. **THIS DRAIN NEEDS TO BE HOOKED UP AS SHOWN.**
- **REMEMBER** no matter how well built a mechanical device may be, eventually they all need service. Plan your installation wisely and include access panels where recommended.
- This bathing system has a removable front cover. Installing this system so the cover cannot be removed will result in damage to finished construction.
- Forcing the door up or down with power and air to the unit **WILL** cause damage to the actuators. Cut power and bleed off air before manually raising or lowering the door.

- TABLE OF CONTENTS PAGE FOR MOST TUB INSTALLATION CONFIGURATIONS -

FINISH		N/A		APOLLO FINISH	
				SPEC NUMBER N/A	
MATERIALS					
ITEM	QTY	P/N	DESCRIPTION	MATERIAL	NOTES
.	.	.	.	.	.

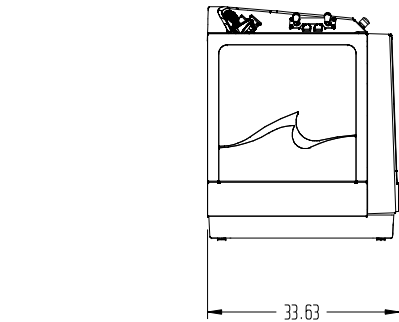

**STRONGLY RECOMMENDED**  
12H x 18W  
ACCESS PANEL  
LOCATED IN WALL

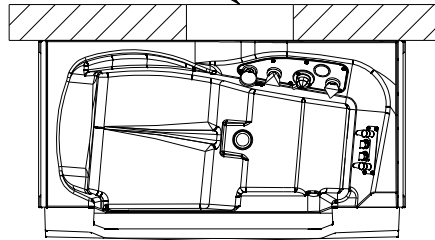

ESSENCE SERIES BACK WALL INSTALLATION

FOR THIS INSTALLATION CONFIGURATION  
PLEASE REFER TO PAGES TWO AND THREE

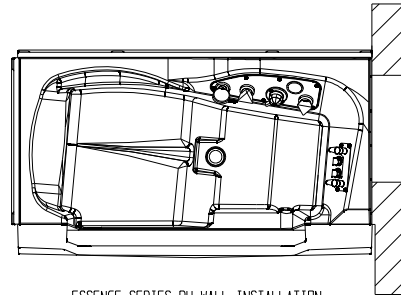
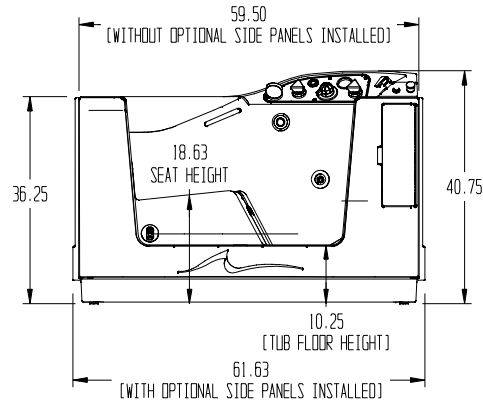

**OPTIONAL**  
12H x 18W  
ACCESS PANEL  
LOCATED IN WALL

ESSENCE SERIES RH WALL INSTALLATION

FOR THIS INSTALLATION CONFIGURATION  
PLEASE REFER TO PAGES TWO AND THREE

PLEASE NOTE:

- 1 - THIS BATHING SYSTEM IS DESIGNED TO BE INSTALLED AFTER ALL CONSTRUCTION AND FINISH WORK IS COMPLETED. THE ABRASIVE NATURE OF DRYWALL DUST AND CONSTRUCTION DEBRIS CAN DAMAGE THE MECHANICAL COMPONENTS AND FINISH OF THE SYSTEM. THIS DAMAGE IS NOT COVERED BY WARRANTY. IF THE UNIT IS INSTALLED DURING CONSTRUCTION, IT IS THE INSTALLER'S RESPONSIBILITY TO ENSURE THE SYSTEM IS ADEQUATELY PROTECTED FROM SUCH CONTAMINANTS.
- 2 - DRAWING VIEWS DEPICT THE MOST TYPICAL ROOM LAYOUTS FOR PLUMBING AND ELECTRICAL LOCATIONS. PLEASE CALL THE TECHNICAL SERVICE DEPARTMENT FOR ALTERNATIVE INSTALLATION LOCATIONS.
- 3 - IT IS STRONGLY RECOMMENDED TO INSTALL ACCESS PANELS THRU WALLS WHERE SHOWN TO AID IN TUB DRAIN CONNECTION AND PREVENTATIVE MAINTENANCE.
- 4 - THE PIVOT CIRCLE ON FLOOR IS 67.5 INCHES (NOMINAL 68 INCHES).
- 5 - THE PIVOT CIRCLE ON VERTICAL EDGE IS 71 INCHES (NOMINAL 71.5 INCHES).
- 6 - DO NOT ALTER DRAIN AND ELECTRICAL LOCATIONS - TUB IS NOT OFFERED AS A RIGHT OR LEFT ENTRY MODEL.

**STRONGLY RECOMMENDED**  
12H x 18W  
ACCESS PANEL  
LOCATED IN WALL

**STRONGLY RECOMMENDED**  
12H x 18W  
ACCESS PANEL  
LOCATED IN WALL

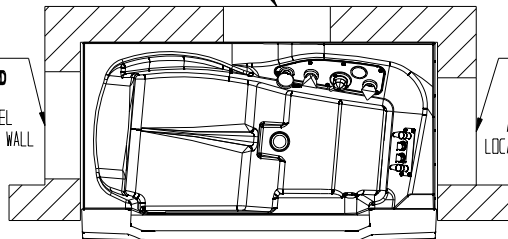

ESSENCE SERIES ALCOVE INSTALLATION

FOR THIS INSTALLATION CONFIGURATION  
PLEASE REFER TO PAGES TWO AND THREE

**STRONGLY RECOMMENDED**  
12H x 18W  
ACCESS PANEL  
LOCATED IN WALL

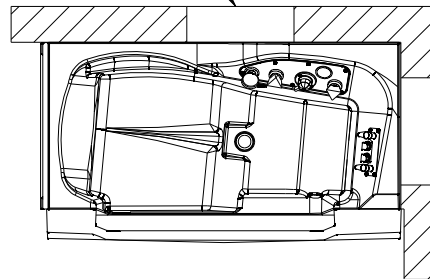

**STRONGLY RECOMMENDED**  
12H x 18W  
ACCESS PANEL  
LOCATED IN WALL

ESSENCE SERIES RH CORNER INSTALLATION

FOR THIS INSTALLATION CONFIGURATION  
PLEASE REFER TO PAGES TWO AND THREE

B	ADDED LEFT AND FRONT ELEVATIONS TO SHEET 1; ADDED SHEET 4; ADDED NOTE DO NOT ALTER	10686	CB 21 JUN 11	SR 22 JUN 11
	A	RELEASED TO PROTOTYPE	10663	T MARA 29 JUN 10
REV	REVISIONS	ED NUMBER	DRWN DATE	APPROVED DATE
<b>APOLLO CORPORATION</b>		TOLERANCE UNLESS SPECIFIED		
PO BOX 219 450 MAIN ST SOMERSET WI 53085		.X	+/- .060 DEGREES +/- 1°	
- NOTICE -		.XX	+/- .030	
THIS DRAWING IS PROPERTY OF APOLLO CORP WHO RESERVES ALL RIGHTS AND IS SUBMITTED UNDER A CONFIDENTIAL RELATIONSHIP. RECIPIENT AGREES NOT TO DISCLOSE ANY INFORMATION REGARDING IT TO ANY UNAUTHORIZED PERSON		.XXX	+/- .015	
1-PARTS TO BE FREE OF BURRS AND SHARP EDGES		2-ALL WELDS MUST BE CONTINUOUS SMOOTH AND FREE OF VOIDS		
3-CORNER BENDS MUST BE FREE OF FRACTURES		SHEET 1 OF 4		
DWG C	ESSENCE ROOM SPECS ROUGH-INS; TUB LOCATIONS	DWG NO 990100-B		

- TUB INSTALLATION ONLY ROUGH-IN INSTRUCTIONS -

GAP REQUIRED BETWEEN TUB FRAME AND WALL (SEE DWG 2)

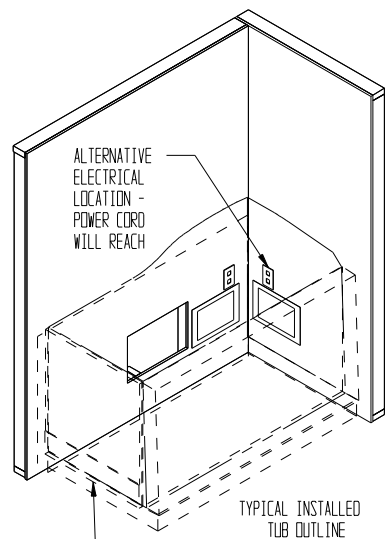
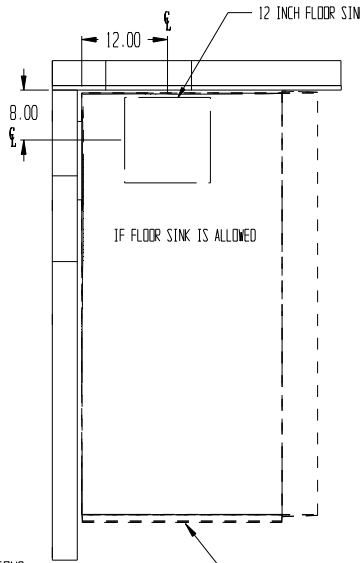
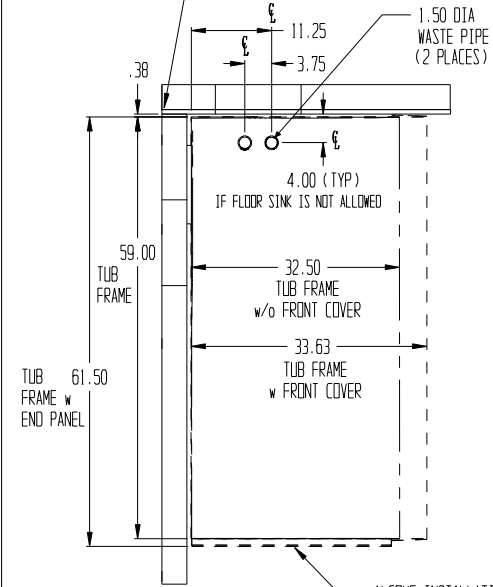

ALCOVE INSTALLATIONS  
**STRONGLY RECOMMENDED**  
 12H x 18W ACCESS PANEL HERE

ALCOVE INSTALLATIONS  
**STRONGLY RECOMMENDED**  
 12H x 18W ACCESS PANEL HERE

ALCOVE INSTALLATIONS  
**STRONGLY RECOMMENDED**  
 12H x 18W ACCESS PANEL HERE

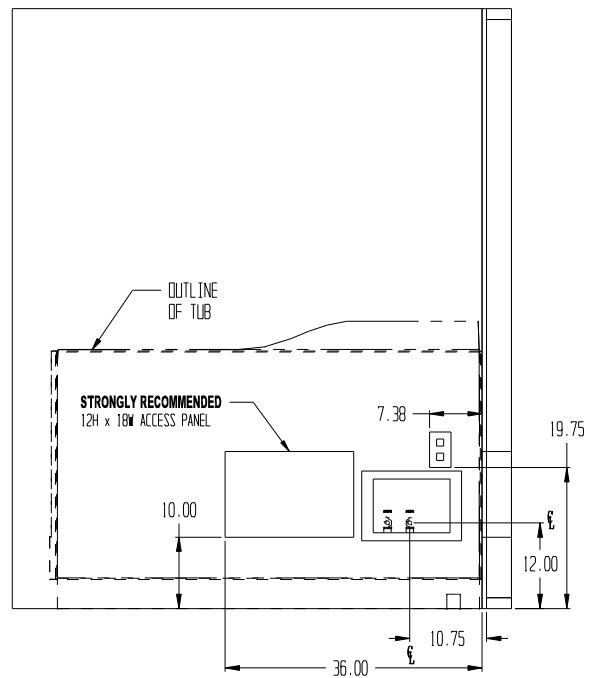
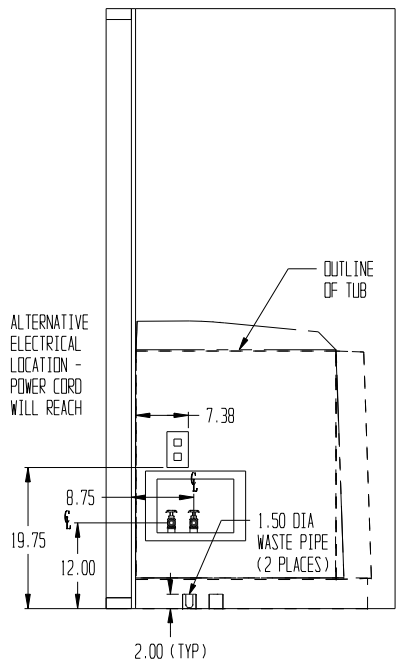

FINISH N/A		APOLLO FINISH SPEC NUMBER N/A	
MATERIALS			
ITEM	QTY	P/N	DESCRIPTION

PLEASE NOTE:

- THIS BATHING SYSTEM IS DESIGNED TO BE INSTALLED AFTER ALL CONSTRUCTION AND FINISH WORK IS COMPLETED. THE ABRASIVE NATURE OF DRYWALL DUST AND CONSTRUCTION DEBRIS CAN DAMAGE THE MECHANICAL COMPONENTS AND FINISH OF THE SYSTEM. THIS DAMAGE IS NOT COVERED BY WARRANTY. IF THE UNIT IS INSTALLED DURING CONSTRUCTION, IT IS THE INSTALLER'S RESPONSIBILITY TO ENSURE THE SYSTEM IS ADEQUATELY PROTECTED FROM SUCH CONTAMINANTS.**
- DRAWING VIEWS DEPICT THE MOST TYPICAL ROOM LAYOUTS FOR PLUMBING AND ELECTRICAL LOCATIONS. PLEASE CALL THE TECHNICAL SERVICE DEPARTMENT FOR ALTERNATIVE INSTALLATION LOCATIONS.
- THE BEST DRAIN CONNECTION IS TO USE A FLOOR SINK - CHECK BUILDING CODES
- TUB COMES WITH A REMOVABLE FRONT PANEL. PLEASE NOTE WHEN ROUGHING IN TUB, THE FRONT PANEL MUST BE EASILY REMOVABLE WHEN INSTALLED.
- IT IS STRONGLY RECOMMENDED TO INSTALL ACCESS PANELS THRU WALLS WHERE SHOWN TO AID IN TUB DRAIN CONNECTION AND PREVENTATIVE MAINTENANCE.**
- THE PIVOT CIRCLE ON FLOOR IS 67.5 INCHES (NOMINAL 68 INCHES).
- THE PIVOT CIRCLE ON VERTICAL EDGE IS 71 INCHES (NOMINAL 71.5 INCHES).
- DO NOT ALTER DRAIN AND ELECTRICAL LOCATIONS - TUB IS NOT OFFERED AS A RIGHT OR LEFT ENTRY MODEL.**

B	ADDED LEFT AND FRONT ELEVATIONS TO SHEET 1; ADDED SHEET 4; ADDED NOTE DO NOT ALTER	10686	CB 21 JUN 11	SR 22 JUN 11
	A	RELEASED TO PROTOTYPE	10663	T MARA 29 JUN 10
REV	REVISIONS	ED NUMBER	DRWN DATE	APPROVED DATE
 APOLLO CORPORATION PO BOX 219 450 MAIN ST SOMERSET W1 (715)247-5825		TOLERANCE UNLESS SPECIFIED		
THIS DRAWING IS PROPERTY OF APOLLO CORP WHO RESERVES ALL RIGHTS AND IS SUBMITTED UNDER A CONFIDENTIAL RELATIONSHIP. RECIPIENT AGREES NOT TO DISCLOSE ANY INFORMATION REGARDING IT TO ANY UNAUTHORIZED PERSON		1-PARTS TO BE FREE OF BURRS AND SHARP EDGES 2-ALL WELDS MUST BE CONTINUOUS SMOOTH AND FREE OF VOIDS 3-CORNER BENDS MUST BE FREE OF FRACTURES		
DWG C	ESSENCE ROOM SPECS ROUGH-INS; TUB LOCATIONS	SHEET 2 OF 4	DWG NO 990100-B	

- TUB INSTALLATION ONLY ROUGH-IN INSTRUCTIONS -

FINISH		N/A		APOLLO FINISH SPEC NUMBER		N/A	
MATERIALS							
ITEM	QTY	P/N	DESCRIPTION			MATERIAL	NOTES

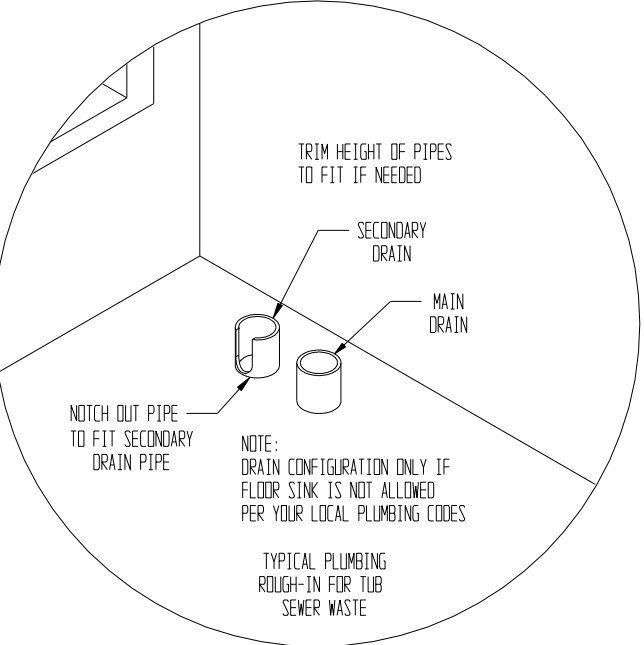

View A  
3:1

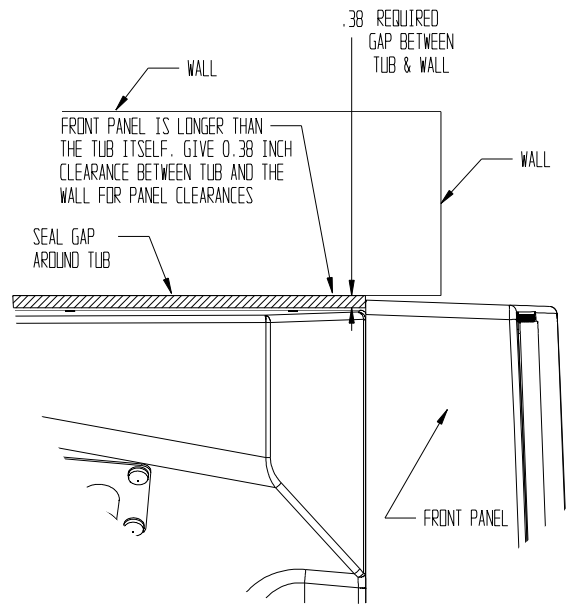

View B  
5:1

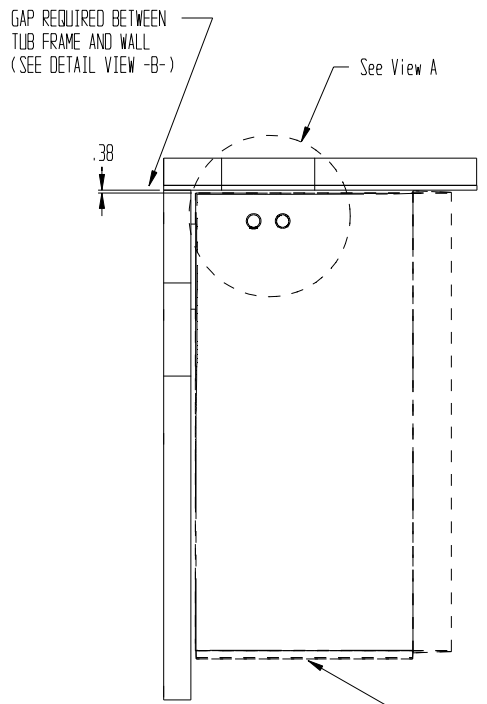

TUB SHOWN AS OUTLINE  
ALCOVE INSTALLATIONS  
**STRONGLY RECOMMENDED**  
12H x 18W ACCESS PANEL HERE

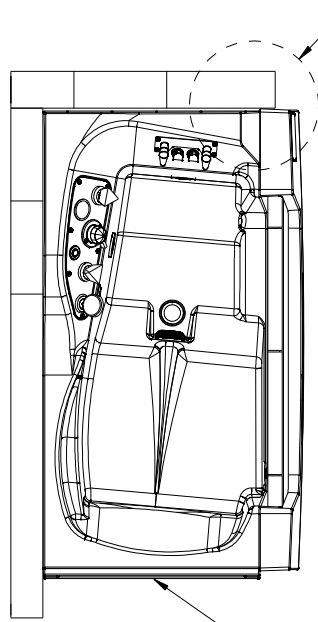

TUB SHOWN INSTALLED  
ALCOVE INSTALLATIONS  
**STRONGLY RECOMMENDED**  
12H x 18W ACCESS PANEL HERE

PLEASE NOTE:

- 1 - THIS BATHING SYSTEM IS DESIGNED TO BE INSTALLED AFTER ALL CONSTRUCTION AND FINISH WORK IS COMPLETED. THE ABRASIVE NATURE OF DRYWALL DUST AND CONSTRUCTION DEBRIS CAN DAMAGE THE MECHANICAL COMPONENTS AND FINISH OF THE SYSTEM. THIS DAMAGE IS NOT COVERED BY WARRANTY. IF THE UNIT IS INSTALLED DURING CONSTRUCTION, IT IS THE INSTALLER'S RESPONSIBILITY TO ENSURE THE SYSTEM IS ADEQUATELY PROTECTED FROM SUCH CONTAMINANTS.
- 2 - DRAWING VIEWS DEPICT THE MOST TYPICAL ROOM LAYOUTS FOR PLUMBING AND ELECTRICAL LOCATIONS. PLEASE CALL THE TECHNICAL SERVICE DEPARTMENT FOR ALTERNATIVE INSTALLATION LOCATIONS.
- 3 - THE BEST DRAIN CONNECTION IS TO USE A FLOOR SINK - CHECK BUILDING CODES
- 4 - TUB COMES WITH A REMOVABLE FRONT PANEL. PLEASE NOTE WHEN ROUGHING IN TUB, THE FRONT PANEL MUST BE EASILY REMOVABLE WHEN INSTALLED. REFER TO VIEW -B-.
- 5 - IT IS STRONGLY RECOMMENDED TO INSTALL ACCESS PANELS THRU WALLS WHERE SHOWN TO AID IN TUB DRAIN CONNECTION AND PREVENTATIVE MAINTENANCE.
- 6 - THE PIVOT CIRCLE ON FLOOR IS 67.5 INCHES (NOMINAL 68 INCHES).
- 7 - THE PIVOT CIRCLE ON VERTICAL EDGE IS 71 INCHES (NOMINAL 71.5 INCHES).
- 8 - PLEASE NOTE - DO NOT ALTER DRAIN AND ELECTRICAL LOCATIONS - TUB IS NOT OFFERED AS A RIGHT OR LEFT ENTRY MODEL

B	ADDED LEFT AND FRONT ELEVATIONS TO SHEET 1; ADDED SHEET 4; ADDED NOTE DO NOT ALTER	CB	21 JUN 11	SR	22 JUN 11
	A	RELEASED TO PROTOTYPE	10663	T MARA	SR
REV	REVISIONS	ED NUMBER	DRAWN DATE	APPROVED DATE	
<b>APOLLO CORPORATION</b>			TOLERANCE UNLESS SPECIFIED		
PO BOX 219 450 MAIN ST SOMERSET VT (715)247-5625			.X	+/- .060 DEGREES	+/- 1°
- NOTICE - THIS DRAWING IS PROPERTY OF APOLLO CORP WHO RESERVES ALL RIGHTS AND IS SUBMITTED UNDER A CONFIDENTIAL RELATIONSHIP. RECIPIENT AGREES NOT TO DISCLOSE ANY INFORMATION REGARDING IT TO ANY UNAUTHORIZED PERSON			.XX	+/- .030	
			.XXX	+/- .015	
1-PARTS TO BE FREE OF BURRS AND SHARP EDGES 2-ALL WELDS MUST BE CONTINUOUS SMOOTH AND FREE OF VOIDS 3-CORNER BENDS MUST BE FREE OF FRACTURES			SHEET (DWG NO)		
			DWG C ESSENCE ROOM SPECS ROUGH-INS; TUB LOCATIONS		

- ALTERNATIVE ALCOVE INSTALLATION -

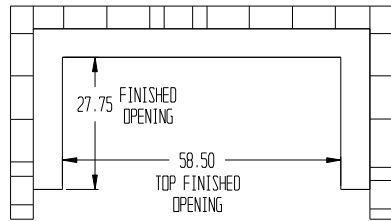

TOP VIEW

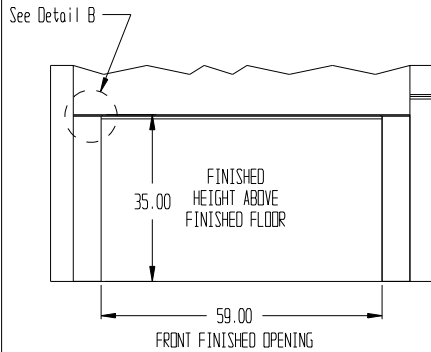

FRONT VIEW

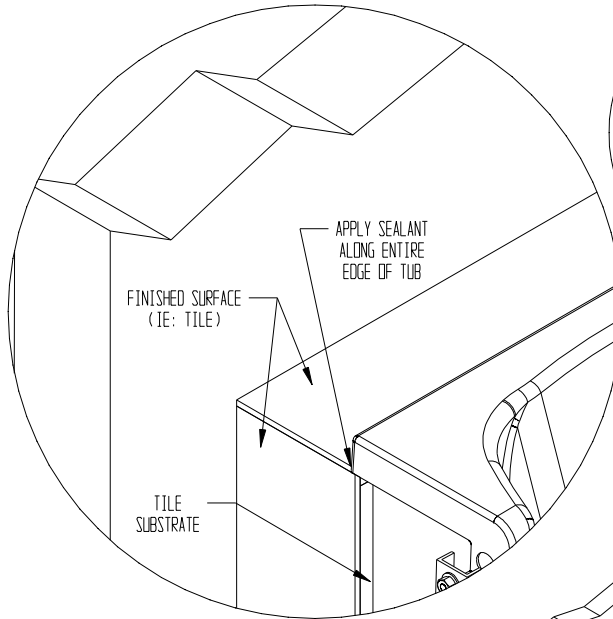

Detail A  
6:1

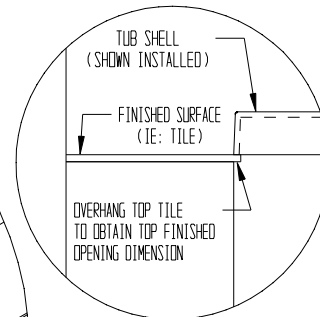

Detail B  
6:1

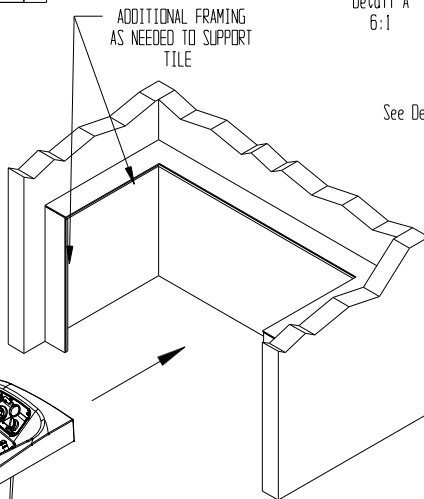

ADDITIONAL FRAMING  
AS NEEDED TO SUPPORT  
TILE

See Detail A

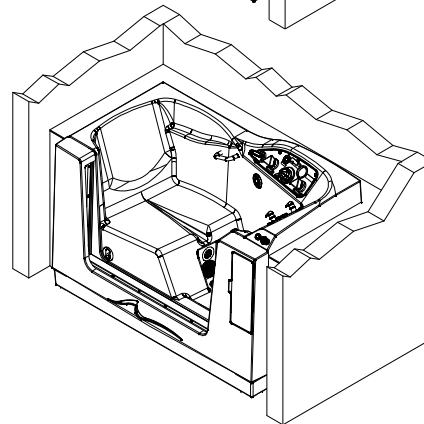
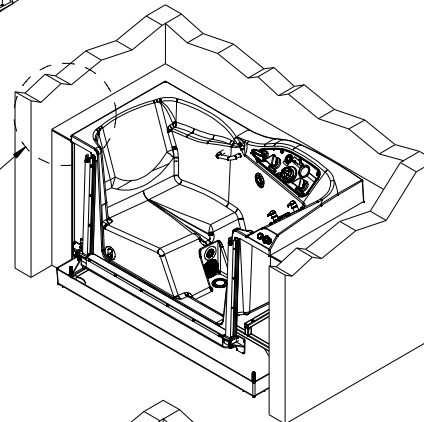

ADJUST LEVELING FEET TO  
RAISE UNIT ABOVE FINISHED  
ALCOVE HEIGHT (4 PLACES)

SOME ITEMS REMOVED FOR CLARITY

FINISH N/A		APOLLO FINISH SPEC NUMBER N/A	
MATERIALS			
ITEM	QTY	P/N	DESCRIPTION

PLEASE NOTE:

- 1 - THIS BATHING SYSTEM IS DESIGNED TO BE INSTALLED AFTER ALL CONSTRUCTION AND FINISH WORK IS COMPLETED. THE ABRASIVE NATURE OF DRYWALL DUST AND CONSTRUCTION DEBRIS CAN DAMAGE THE MECHANICAL COMPONENTS AND FINISH OF THE SYSTEM. THIS DAMAGE IS NOT COVERED BY WARRANTY. IF THE UNIT IS INSTALLED DURING CONSTRUCTION, IT IS THE INSTALLER'S RESPONSIBILITY TO ENSURE THE SYSTEM IS ADEQUATELY PROTECTED FROM SUCH CONTAMINANTS.
- 2 - DRAWING VIEWS DEPICT THE MOST TYPICAL ROOM LAYOUTS FOR PLUMBING AND ELECTRICAL LOCATIONS. PLEASE CALL THE TECHNICAL SERVICE DEPARTMENT FOR ALTERNATIVE INSTALLATION LOCATIONS.
- 3 - THE BEST DRAIN CONNECTION IS TO USE A FLOORSINK - CHECK BUILDING CODES
- 4 - TUB COMES WITH A REMOVABLE FRONT PANEL. PLEASE NOTE WHEN ROUGHING IN TUB, THE FRONT PANEL MUST BE EASILY REMOVABLE WHEN INSTALLED. REFER TO VIEW -B-.
- 5 - IT IS STRONGLY RECOMMENDED TO INSTALL ACCESS PANELS THRU WALLS WHERE SHOWN TO AID IN TUB DRAIN CONNECTION AND PREVENTATIVE MAINTENANCE.
- 6 - THE PIVOT CIRCLE ON FLOOR IS 67.5 INCHES (NOMINAL 68 INCHES)
- 7 - THE PIVOT CIRCLE ON VERTICAL EDGE IS 71 INCHES (NOMINAL 71.5 INCHES).
- 8 - PLEASE NOTE - DO NOT ALTER DRAIN AND ELECTRICAL LOCATIONS - TUB IS NOT OFFERED AS A RIGHT OR LEFT ENTRY MODEL

B	ADDED LEFT AND FRONT ELEVATIONS TO SHEET 1; ADDED SHEET 4; ADDED NOTE DO NOT ALTER	10686	CB	21 JUN 11	SR	22 JUN 11
A	RELEASED TO PROTOTYPE	10663	T MARA	29 JUN 10	SR	11 NOV 10
REV	REVISIONS	ED NUMBER	DRWN DATE	APPROVED DATE		

**APOLLO CORPORATION**

PO BOX 219 450 MAIN ST SOMERSET VT (715) 247-5825

- NOTICE -

THIS DRAWING IS PROPERTY OF APOLLO CORP WHO RESERVES ALL RIGHTS AND IS SUBMITTED UNDER A CONFIDENTIAL RELATIONSHIP. RECIPIENT AGREES NOT TO DISCLOSE ANY INFORMATION REGARDING IT TO ANY UNAUTHORIZED PERSON

TOLERANCE UNLESS SPECIFIED  
.X +/- .060 DEGREES +/- 1°  
.XX +/- .030  
.XXX +/- .015

1-PARTS TO BE FREE OF BURRS AND SHARP EDGES  
2-ALL WELDS MUST BE CONTINUOUS SMOOTH AND FREE OF VOIDS  
3-CORNER BENDS MUST BE FREE OF FRACTURES

DWG C ESSENCE ROOM SPECS ROUGH-INS; TUB LOCATIONS SHEET 4 OF 4 DWG NO 990100-B